

# Pressure regulator, Series NL4-RGS

- G 1/2 G 3/4
- Qn = 9500 l/min
- Standard pressure regulator
- Activation Mechanical
- lockable
- with key
- suitable for ATEX



Parts	Pressure regulator
Mounting orientation	Any
Certificates	suitable for ATEX
Working pressure min./max.	0,5 ... 16 bar
Ambient temperature min./max.	-10 ... 60 °C
Medium temperature min./max.	-10 ... 60 °C
Medium	Compressed air Neutral gases
Regulator type	Diaphragm-type pressure regulator Can be assembled into blocks with relieving air exhaust
Regulator function	See table below
Adjustment range min./max.	with key
Lock type	single
Pressure supply	Mechanical
Activation	See table below
Weight	

## Technical data

Part No.	[Symbol]	[Symbol]	Port	Flow	Adjustment range min./max.	Pressure gauge
				Qn		
0821302581	[Symbol]	[Symbol]	G 1/2	9500 l/min	0,1 ... 3 bar	with pressure gauge
0821302582	[Symbol]	[Symbol]	G 1/2	9500 l/min	0,2 ... 6 bar	with pressure gauge
0821302502	[Symbol]	[Symbol]	G 1/2	9500 l/min	0,5 ... 10 bar	with pressure gauge
0821302583	[Symbol]	—	G 1/2	9500 l/min	0,1 ... 3 bar	-
0821302584	[Symbol]	—	G 1/2	9500 l/min	0,2 ... 6 bar	-
0821302503	[Symbol]	—	G 1/2	9500 l/min	0,5 ... 10 bar	-
0821302548	[Symbol]	[Symbol]	G 3/4	9500 l/min	0,1 ... 3 bar	with pressure gauge
0821302549	[Symbol]	[Symbol]	G 3/4	9500 l/min	0,2 ... 6 bar	with pressure gauge
0821302542	[Symbol]	[Symbol]	G 3/4	9500 l/min	0,5 ... 10 bar	with pressure gauge
0821302543	[Symbol]	—	G 3/4	9500 l/min	0,5 ... 10 bar	-

Part No.	Weight
0821302581	0,935 kg
0821302582	0,935 kg
0821302502	0,935 kg
0821302583	0,85 kg
0821302584	0,85 kg
0821302503	0,85 kg
0821302548	0,935 kg
0821302549	0,935 kg

Part No.	Weight
0821302542	0,935 kg
0821302543	0,85 kg

Nominal flow  $Q_n$  with secondary pressure  $p_2 = 6$  bar at  $\Delta p = 1$  bar

Suitable for use in Ex zones 1, 2, 21, 22.

## Technical information

The pressure dew point must be at least 15 °C under ambient and medium temperature and may not exceed 3 °C .

Suitable for use in Ex zones 1, 2, 21, 22.

A change in the flow direction (from air supply on the left to air supply on the right) occurs by rotating installation by 180° about the vertical axis. Please see the operating instructions for further details.

The rear pressure gauge connection on the pressure regulator is closed with a blanking plug, the front connection is open. Depending on the customer application, a second blanking plug may be necessary. Please order separately (see accessories).

Relieving exhaust ( $\leq 0.3$  bar over set pressure).

With rear exhaust ( $> 3$  bar ).

Recommended pre-filtering 5  $\mu$ m

## Technical information

Material	
Housing	Die cast zinc
Front plate	Acrylonitrile butadiene styrene
Seals	Acrylonitrile butadiene rubber

# Dimensions

## Dimensions

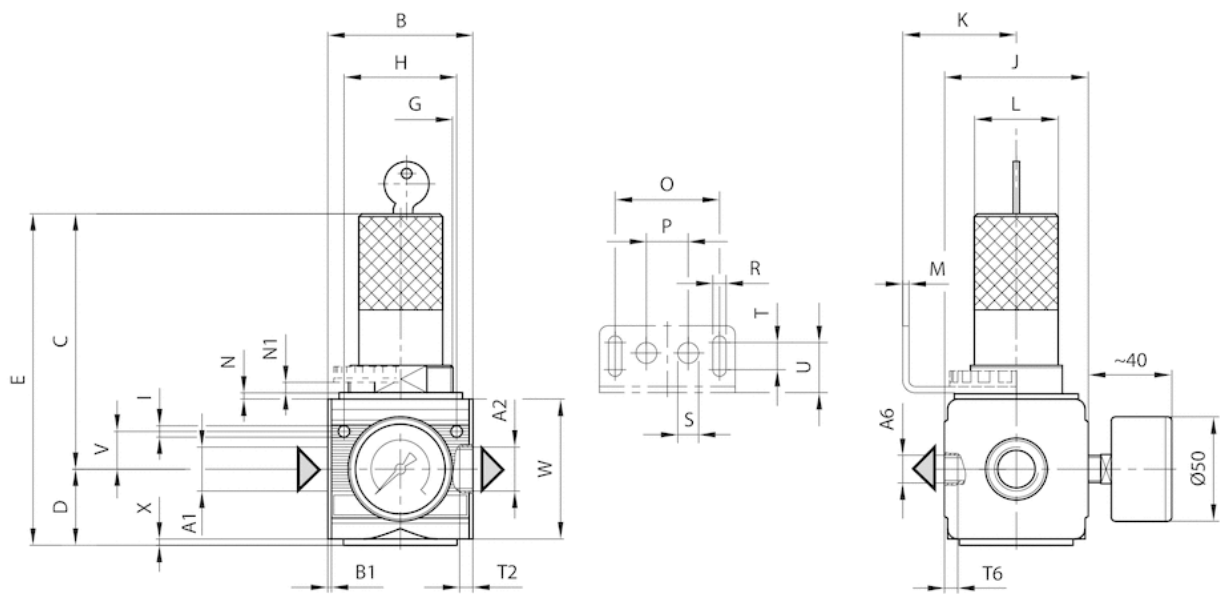

A1 = input  
 A2 = output  
 A6 = output

## Dimensions in mm

A1	A2	A6	B	B1	C	D	E	G	H	I	J	K	L	M	N	N1	O	P	R	S	T	T2
G 1/2	G 1/2	G 1/4	69.5	1.8	122	35.5	157.5	M50x1,5	54	5.5	67	54.5	46	3	3	5.5	50	20	6.4	10	13	13
G 3/4	G 3/4	G 1/4	69.5	1.8	122	35.5	157.5	M50x1,5	54	5.5	67	54.5	46	3	3	5.5	50	20	6.4	10	13	13

T6	U	V	W	X
7	24	18	67	2
7	24	18	67	2

Diagrams

Pressure characteristics curve

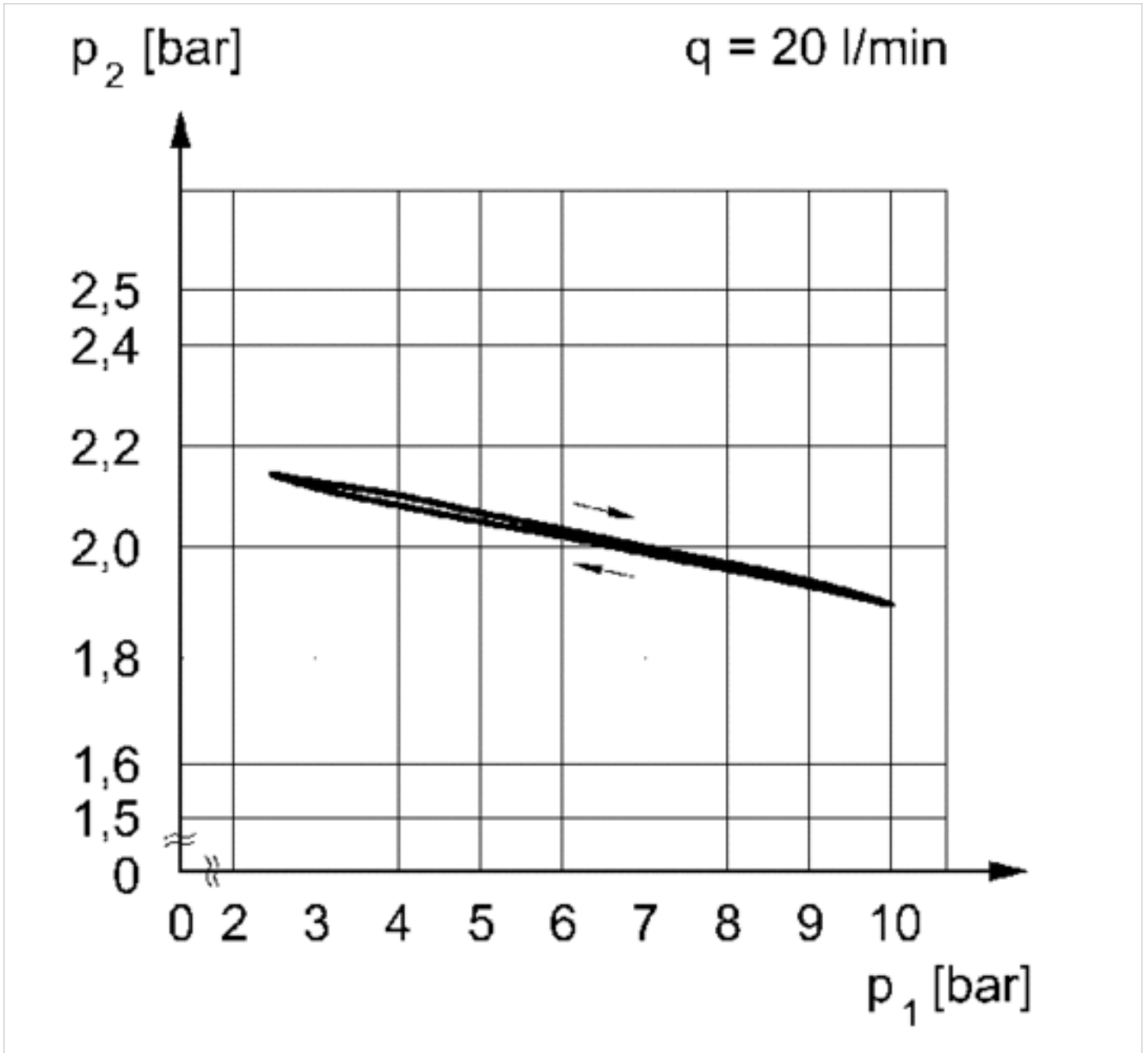

p1 = working pressure  
 p2 = secondary pressure  
 q = flow rate

Flow rate characteristic (setting range p2: 0.5 - 10 bar)

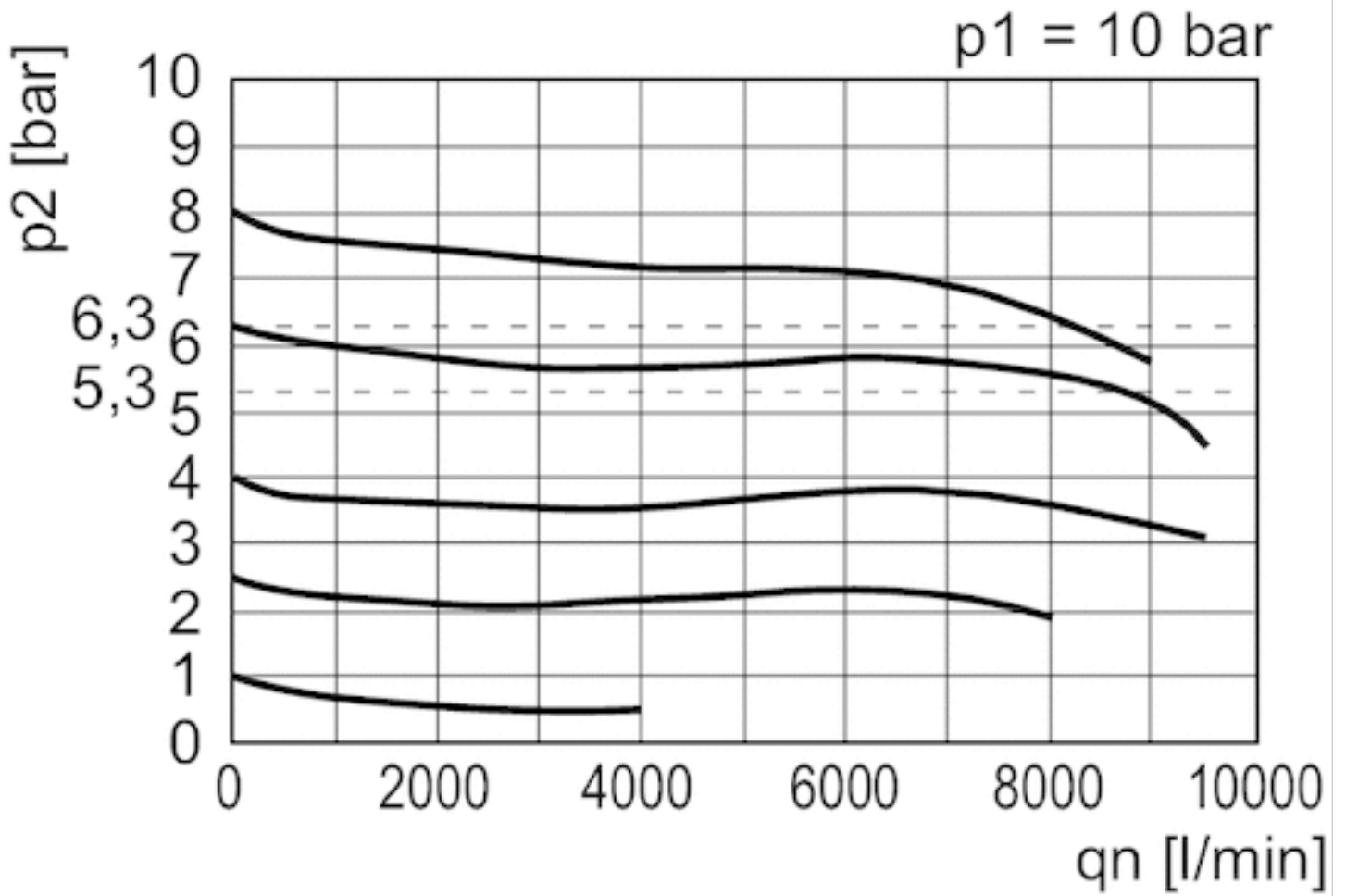

p1 = Working pressure  
p2 = Secondary pressure  
qn = Nominal flow

# Efficient pneumatic solutions, our program: cylinders and drives, valves and valve systems, air supply management



Visit us: [Emerson.com/Aventics](https://www.emerson.com/Aventics)

Your local contact: [Emerson.com/contactus](https://www.emerson.com/contactus)



[Emerson.com](https://www.emerson.com)



[Facebook.com/EmersonAutomationSolutions](https://www.facebook.com/EmersonAutomationSolutions)



[LinkedIn.com/company/Emerson-Automation-Solutions](https://www.linkedin.com/company/Emerson-Automation-Solutions)



[Twitter.com/EMR\\_Automation](https://twitter.com/EMR_Automation)

An example configuration is depicted on the title page. The delivered product may thus vary from that in the illustration. Subject to change. This Document, as well as the data, specifications and other information set forth in it, are the exclusive property of AVENTICS GmbH. It may not be reproduced or given to third parties without its consent. Only use the AVENTICS products shown in industrial applications. Read the product documentation completely and carefully before using the product. Observe the applicable regulations and laws of the respective country. When integrating the product into applications, note the system manufacturer's specifications for safe use of the product. The data specified only serve to describe the product. No statements concerning a certain condition or suitability for a certain application can be derived from our information. The information given does not release the user from the obligation of own judgement and verification. It must be remembered that the products are subject to a natural process of wear and aging.

The Emerson logo is a trademark and service mark of Emerson Electric Co. Brand logotype are registered trademarks of one of the Emerson family of companies. All other marks are the property of their respective owners. © 2020 Emerson Electric Co. All rights reserved.  
2020-12



## CONSIDER IT SOLVED™