

Profilzylinder ISO 15552, Serie PRA - inch

- Ø 32-125 mm
- Anschlüsse 1/8 NPT 1/4 NPT 3/8 NPT 1/2 NPT
- doppelwirkend
- mit Magnetkolben
- Dämpfung pneumatisch, pneumatisch einstellbar
- Kolbenstange Außengewinde
- Kolbenstange durchgehend
- ATEX optional

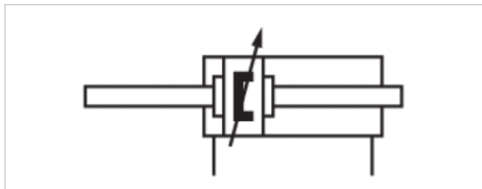

Druckluftanschluss	Innengewinde
Betriebsdruck min./max.	2 ... 10 bar
Umgebungstemperatur min./max.	-20 ... 80 °C
Mediumtemperatur min./max.	-20 ... 80 °C
Medium	Druckluft
Max. Partikelgröße	50 µm
Ölgehalt der Druckluft	0 ... 5 mg/m ³
Druck zur Bestimmung der Kolbenkräfte	6.3 bar



Technische Daten

Kolben-Ø Kolbenstangengewinde Anschlüsse Kolbenstangen-Ø	32 mm 7/16-20 UNF 1/8 NPT 12 mm	40 mm 1/2-20 UNF 1/4 NPT 16 mm	50 mm 3/4-16 UNF 1/4 NPT 20 mm	63 mm 3/4-16 UNF 3/8 NPT 20 mm	80 mm 3/4-16 UNF 3/8 NPT 25 mm	100 mm 3/4-16 UNF 1/2 NPT 25 mm
Hub 25.4	R480176152	R480176240	R480176332	R480176414	R480176507	R480176597
50.8	R480176160	R480176248	R480176341	R480176423	R480176517	R480176604
76.2	R480176173	R480176255	R480176348	R480176435	R480176519	R480176612
101.6	R480176175	R480176267	R480176356	R480176440	R480176533	R480176615
127	R480176182	R480176276	R480176359	R480176448	R480176535	R480176625
152.4	R480176191	R480176283	R480176366	R480176454	R480176542	R480176630
177.8	R480176204	R480176289	R480176378	R480176463	R480176555	R480176645
203.2	R480176212	R480176300	R480176389	R480176477	R480176559	R480176651
228.6	R480176214	R480176308	R480176391	R480176481	R480176573	R480176659
254	R480176226	R480176313	R480176404	R480176489	R480176577	R480176667
304.8	R480176236	R480176319	R480176408	R480176496	R480176582	R480176674

Kolben-Ø Kolbenstangengewinde Anschlüsse Kolbenstangen-Ø	125 mm 1-14 UNF 1/2 NPT 32 mm
Hub 25.4	R480176680
50.8	R480176693
76.2	R480176700
101.6	R480176706
127	R480176715
152.4	R480176724
177.8	R480176726
203.2	R480176740
228.6	R480176749
254	R480176750
304.8	R480176762

Technische Daten

Kolben-Ø	32 mm	40 mm	50 mm	63 mm	80 mm	100 mm	125 mm
Kolbenkraft einfahrend	435 N	660 N	1035 N	1765 N	2855 N	4635 N	7220 N
Kolbenkraft ausfahrend	435 N	660 N	1035 N	1765 N	2855 N	4635 N	7220 N
Dämpfungslänge	16,5 mm	19 mm	17 mm	16,5 mm	19,5 mm	19,5 mm	22 mm
Dämpfungsenergie	4,8 J	9 J	15 J	27 J	54 J	88 J	140 J
Gewicht 0 mm Hub	0,58 kg	0,8 kg	1,34 kg	1,72 kg	2,92 kg	4,08 kg	8,92 kg
Gewicht +10 mm Hub	0,031 kg	0,048 kg	0,072 kg	0,079 kg	0,124 kg	0,139 kg	0,22 kg
Hub max.	1600 mm	1900 mm	2100 mm	2500 mm	2800 mm	2800 mm	2750 mm

Technische Informationen

Der Drucktaupunkt muss mindestens 15 °C unter der Umgebungs- und Mediumtemperatur liegen und darf max. 3 °C betragen. Der Ölgehalt der Druckluft muss über die gesamte Lebensdauer konstant bleiben. Verwenden Sie ausschließlich von AVENTICS zugelassene Öle. Weitere Informationen finden Sie im Dokument „Technische Informationen“ (erhältlich im MediaCentre).

Technische Informationen

Werkstoff	
Zylinderrohr	Aluminium, eloxiert
Kolbenstange	Nichtrostender Stahl
Deckel vorne	Aluminium-Druckguss
Deckel hinten	Aluminium-Druckguss
Dichtung	Polyurethan
Mutter für Kolbenstange	Stahl, verzinkt
Abstreifer	Polyurethan

Abmessungen

Abmessungen

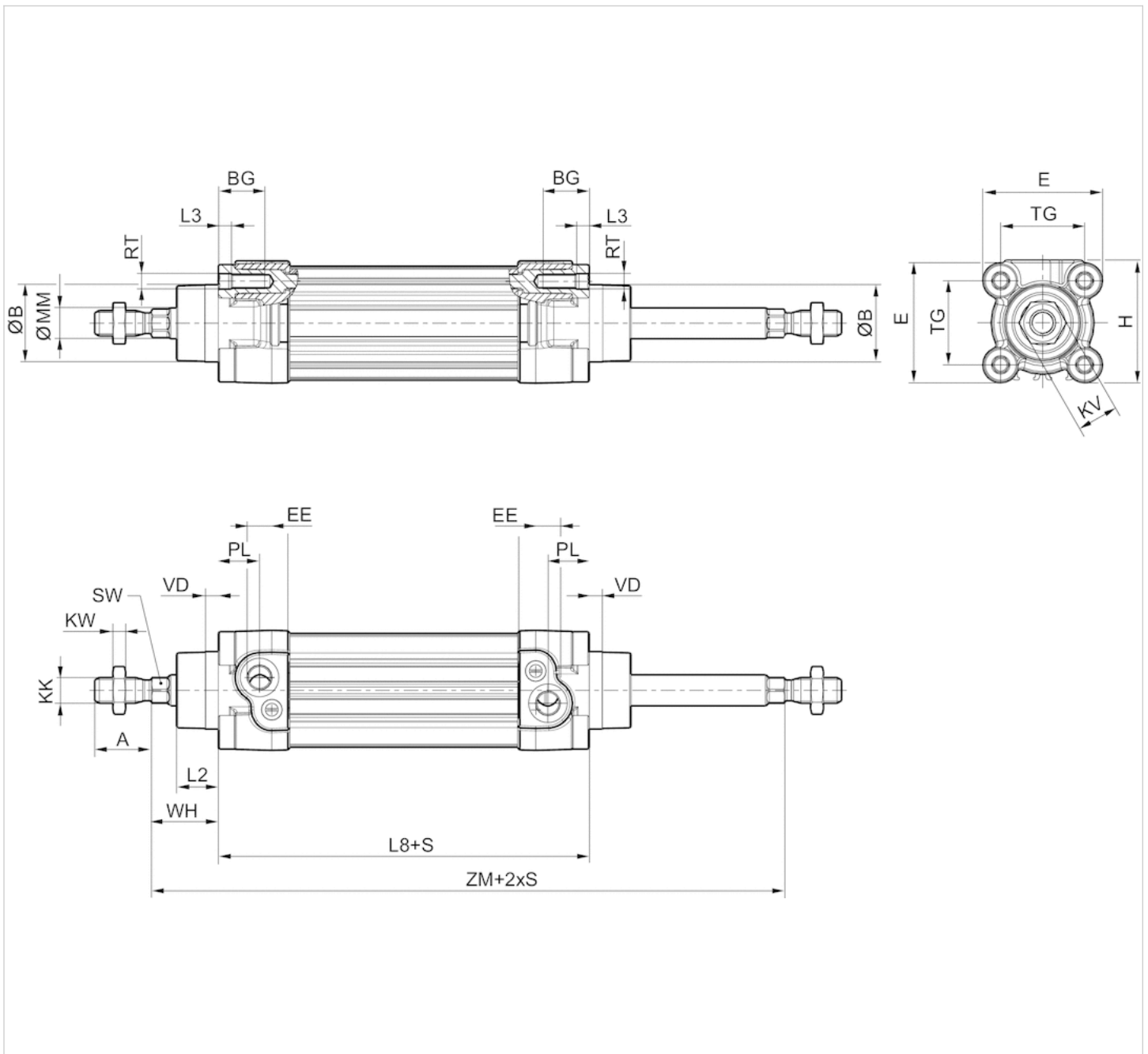

S = Hub

Abmessungen

Kolben-Ø	A -2	ØB d11	BG min.	E	EE inch	EE	H	KK inch	KK	KV	KW
32 mm	22	30	16	46.5	1/8 NPT	G 1/8	47.5	7/16 - 20 UNF	M10x1,25	16	5
40 mm	24	35	16	53	1/4 NPT	G 1/4	53	1/2 - 20 UNF	M12x1,25	18	6
50 mm	32	40	16	65	1/4 NPT	G 1/4	65	3/4 - 16 UNF	M16x1,5	24	8
63 mm	32	45	16	75	3/8 NPT	G 3/8	75	3/4 - 16 UNF	M16x1,5	24	8
80 mm	40	45	17	95	3/8 NPT	G 3/8	95	3/4 - 16 UNF	M20x1,5	30	10
100 mm	40	55	17	115	1/2 NPT	G 1/2	115	3/4 - 16 UNF	M20x1,5	30	10

Kolben-Ø	A -2	ØB d11	BG min.	E	EE inch	EE	H	KK inch	KK	KV	KW
125 mm	54	60	20	140	1/2 NPT	G 1/2	140	1 - 14 UNF	M27x2	41	13.5

Kolben-Ø	ØMM f8	PL	L2	L3 ±0,5	L8	RT	SW	TG	VD	WH	ZM
32 mm	12	16	16.25	4.5	94±0,4	M6	10	32,5±0,5	5	26±1,4	146+3/-1,5
40 mm	16	20	18.25	4.5	105±0,7	M6	13	38±0,5	5	30±1,4	165+3/-1,5
50 mm	20	19	25	4.5	106±0,7	M8	17	46,5±0,6	5	37±1,4	180+3/-1,5
63 mm	20	24	25	4.5	121±0,8	M8	17	56,5±0,7	5	37±1,8	195+3/-1,5
80 mm	25	23.5	33	0	128±0,8	M10	22	72±0,7	5	46±1,8	220+3/-1,5
100 mm	25	25	36	0	138±1	M10	22	89±0,7	5	51±1,8	240+3,5/-2
125 mm	32	33	45	0	160±1	M12	27	110±1,1	7	65±2,2	290+3,5/-2

Diagramme

Dämpfungsdiagramm

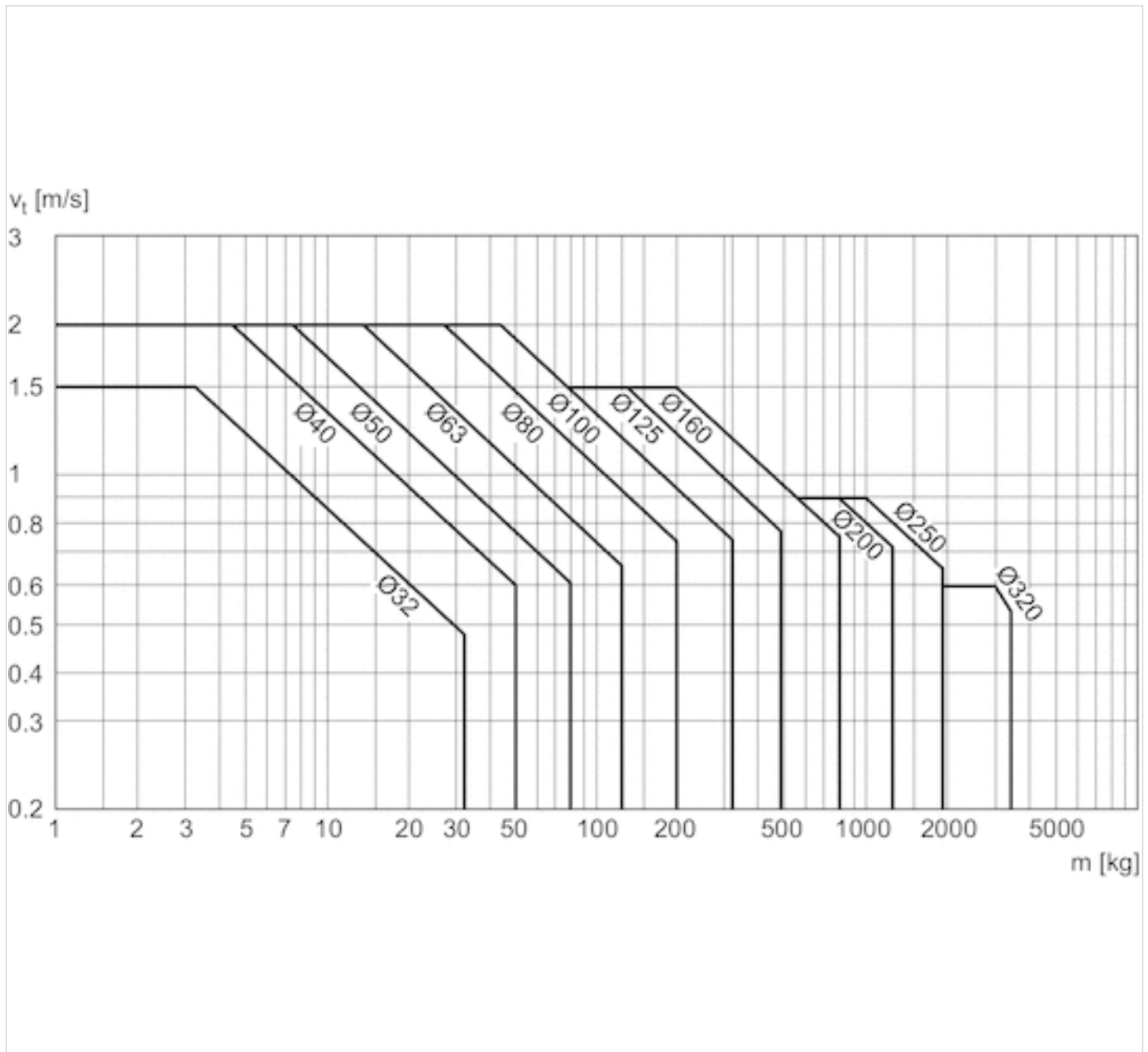

v = Kolbengeschwindigkeit [m/s]

m = Dämpfbare Masse [kg]

Zubehörübersicht

Übersichtszeichnung

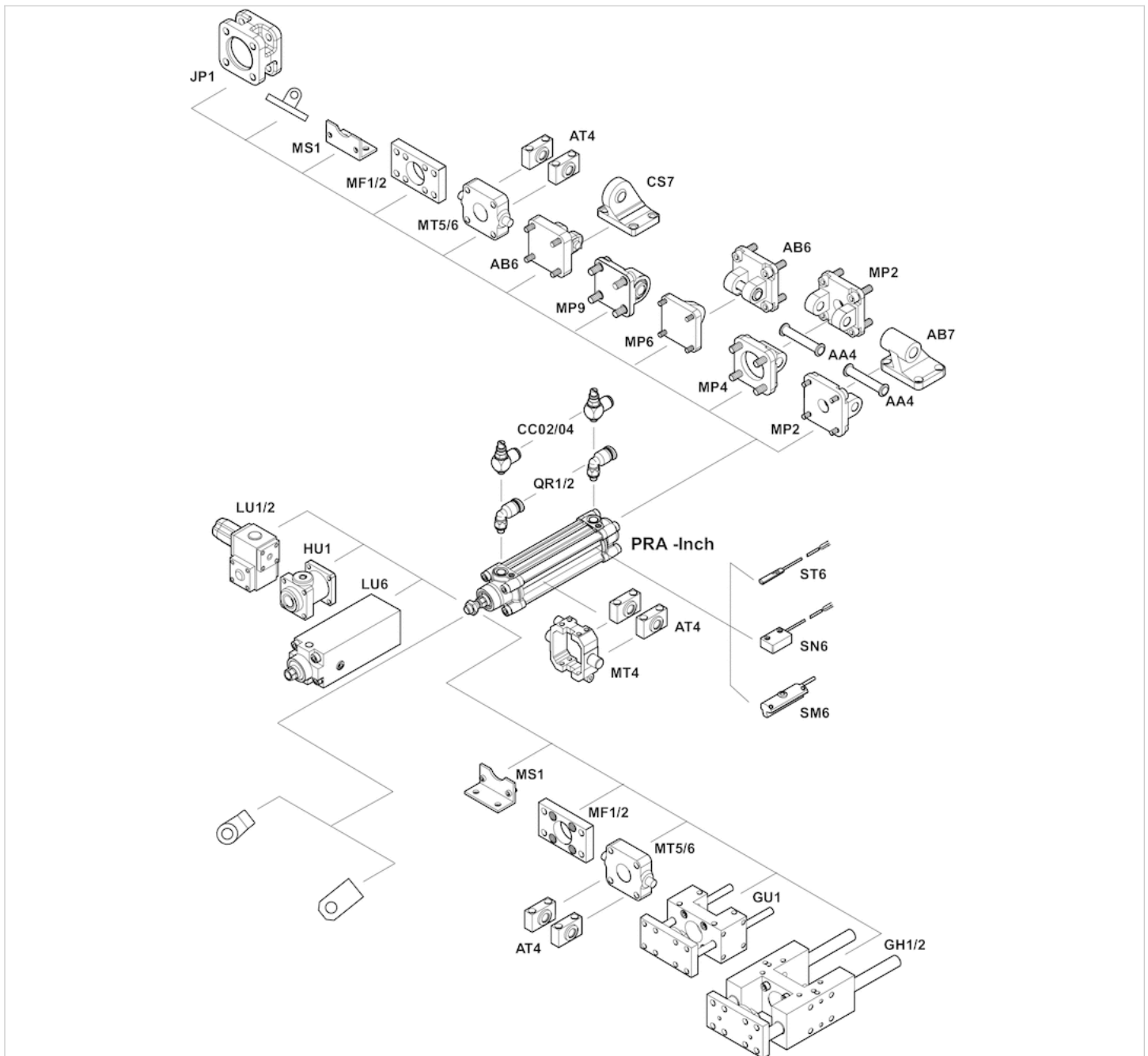

HINWEIS:

Diese Übersichtszeichnung dient zur Orientierung, an welcher Stelle die unterschiedlichen Zubehörteile am Zylinder befestigt werden können. Dazu wurde die Darstellung vereinfacht. Eine konkrete Ableitung maßlicher Gegebenheiten ist deshalb nicht zulässig.

Efficient pneumatic solutions, our program: cylinders and drives, valves and valve systems, air supply management



Visit us: [Emerson.com/Aventics](https://www.emerson.com/Aventics)

Your local contact: [Emerson.com/contactus](https://www.emerson.com/contactus)



[Emerson.com](https://www.emerson.com)



[Facebook.com/EmersonAutomationSolutions](https://www.facebook.com/EmersonAutomationSolutions)



[LinkedIn.com/company/Emerson-Automation-Solutions](https://www.linkedin.com/company/Emerson-Automation-Solutions)



[Twitter.com/EMR_Automation](https://twitter.com/EMR_Automation)

An example configuration is depicted on the title page. The delivered product may thus vary from that in the illustration. Subject to change. This Document, as well as the data, specifications and other information set forth in it, are the exclusive property of AVENTICS GmbH. It may not be reproduced or given to third parties without its consent. Only use the AVENTICS products shown in industrial applications. Read the product documentation completely and carefully before using the product. Observe the applicable regulations and laws of the respective country. When integrating the product into applications, note the system manufacturer's specifications for safe use of the product. The data specified only serve to describe the product. No statements concerning a certain condition or suitability for a certain application can be derived from our information. The information given does not release the user from the obligation of own judgement and verification. It must be remembered that the products are subject to a natural process of wear and aging.

The Emerson logo is a trademark and service mark of Emerson Electric Co. Brand logotype are registered trademarks of one of the Emerson family of companies. All other marks are the property of their respective owners. © 2020 Emerson Electric Co. All rights reserved.
2020-12



CONSIDER IT SOLVED™