

Profilzylinder ISO 15552, Serie PRA - inch

- Ø 32-125 mm
- Anschlüsse 1/8 NPT 1/4 NPT 3/8 NPT 1/2 NPT
- doppelwirkend
- mit Magnetkolben
- Dämpfung pneumatisch, pneumatisch einstellbar
- Kolbenstange Außengewinde

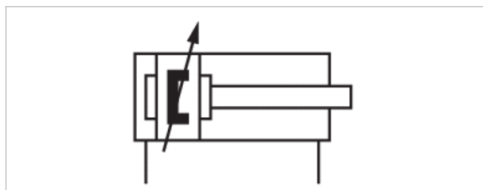

Druckluftanschluss	Innengewinde
Umgebungstemperatur min./max.	-20 ... 80 °C
Mediumtemperatur min./max.	-20 ... 80 °C
Medium	Druckluft
Max. Partikelgröße	50 µm
Ölgehalt der Druckluft	0 ... 5 mg/m ³
Druck zur Bestimmung der Kolbenkräfte	6.3 bar

Technische Daten

Kolben-Ø Kolbenstangengewinde Anschlüsse Kolbenstangen-Ø	32 mm 7/16-20 UNF 1/8 NPT 12 mm	40 mm 1/2-20 UNF 1/4 NPT 16 mm	50 mm 3/4-16 UNF 1/4 NPT 20 mm	63 mm 3/4-16 UNF 3/8 NPT 20 mm	80 mm 3/4-16 UNF 3/8 NPT 25 mm	100 mm 3/4-16 UNF 1/2 NPT 25 mm
Hub 25.4	R480176154	R480176238	R480176328	R480176417	R480176506	R480176593
50.8	R480176162	R480176251	R480176334	R480176427	R480176510	R480176601
76.2	R480176169	R480176257	R480176345	R480176437	R480176523	R480176609
101.6	R480176174	R480176263	R480176354	R480176441	R480176526	R480176614
127	R480176187	R480176275	R480176363	R480176452	R480176534	R480176626
152.4	R480176190	R480176280	R480176370	R480176459	R480176546	R480176633
177.8	R480176201	R480176293	R480176377	R480176464	R480176554	R480176641
203.2	R480176209	R480176298	R480176383	R480176472	R480176561	R480176646
228.6	R480176218	R480176304	R480176395	R480176480	R480176567	R480176660
254	R480176228	R480176316	R480176400	R480176490	R480176581	R480176665
304.8	R480176232	R480176321	R480176412	R480176500	R480176585	R480176676

Kolben-Ø Kolbenstangengewinde Anschlüsse Kolbenstangen-Ø	125 mm 1-14 UNF 1/2 NPT 32 mm
Hub 25.4	R480176685
50.8	R480176689
76.2	R480176694
101.6	R480176707
127	R480176712
152.4	R480176721
177.8	R480176729
203.2	R480176736
228.6	R480176746
254	R480176754
304.8	R480176761

Technische Daten

Kolben-Ø	32 mm	40 mm	50 mm	63 mm	80 mm
Kolbenkraft einfahrend	435 N	660 N	1035 N	1765 N	2855 N
Kolbenkraft ausfahrend	505 N	790 N	1235 N	1960 N	3165 N
Dämpfungslänge	16,5 mm	19 mm	17 mm	16,5 mm	19,5 mm
Dämpfungsenergie	4,8 J	9 J	15 J	27 J	54 J
Gewicht 0 mm Hub	0,5 kg	0,65 kg	1,06 kg	1,42 kg	2,37 kg
Gewicht +10 mm Hub	0,022 kg	0,032 kg	0,047 kg	0,054 kg	0,085 kg
Betriebsdruck min./max.	2 ... 10 bar	2 ... 10 bar	2 ... 10 bar	2 ... 10 bar	2 ... 10 bar
Hub max.	1600 mm	1900 mm	2100 mm	2500 mm	2800 mm

Kolben-Ø	100 mm	125 mm
Kolbenkraft einfahrend	4635 N	7220 N
Kolbenkraft ausfahrend	4945 N	7725 N
Dämpfungslänge	19,5 mm	22 mm
Dämpfungsenergie	88 J	140 J
Gewicht 0 mm Hub	3,51 kg	6,72 kg
Gewicht +10 mm Hub	0,1 kg	0,15 kg
Betriebsdruck min./max.	2 ... 10 bar	2 ... 10 bar
Hub max.	2800 mm	2750 mm

Technische Informationen

Der Drucktaupunkt muss mindestens 15 °C unter der Umgebungs- und Mediumstemperatur liegen und darf max. 3 °C betragen.

Der Ölgehalt der Druckluft muss über die gesamte Lebensdauer konstant bleiben.

Verwenden Sie ausschließlich von AVENTICS zugelassene Öle. Weitere Informationen finden Sie im Dokument „Technische Informationen“ (erhältlich im MediaCentre).

Technische Informationen

Werkstoff	
Zylinderrohr	Aluminium, eloxiert
Kolbenstange	Nichtrostender Stahl
Deckel vorne	Aluminium-Druckguss
Deckel hinten	Aluminium-Druckguss
Dichtung	Polyurethan
Mutter für Kolbenstange	Stahl, verzinkt
Abstreifer	Polyurethan

Abmessungen

Abmessungen

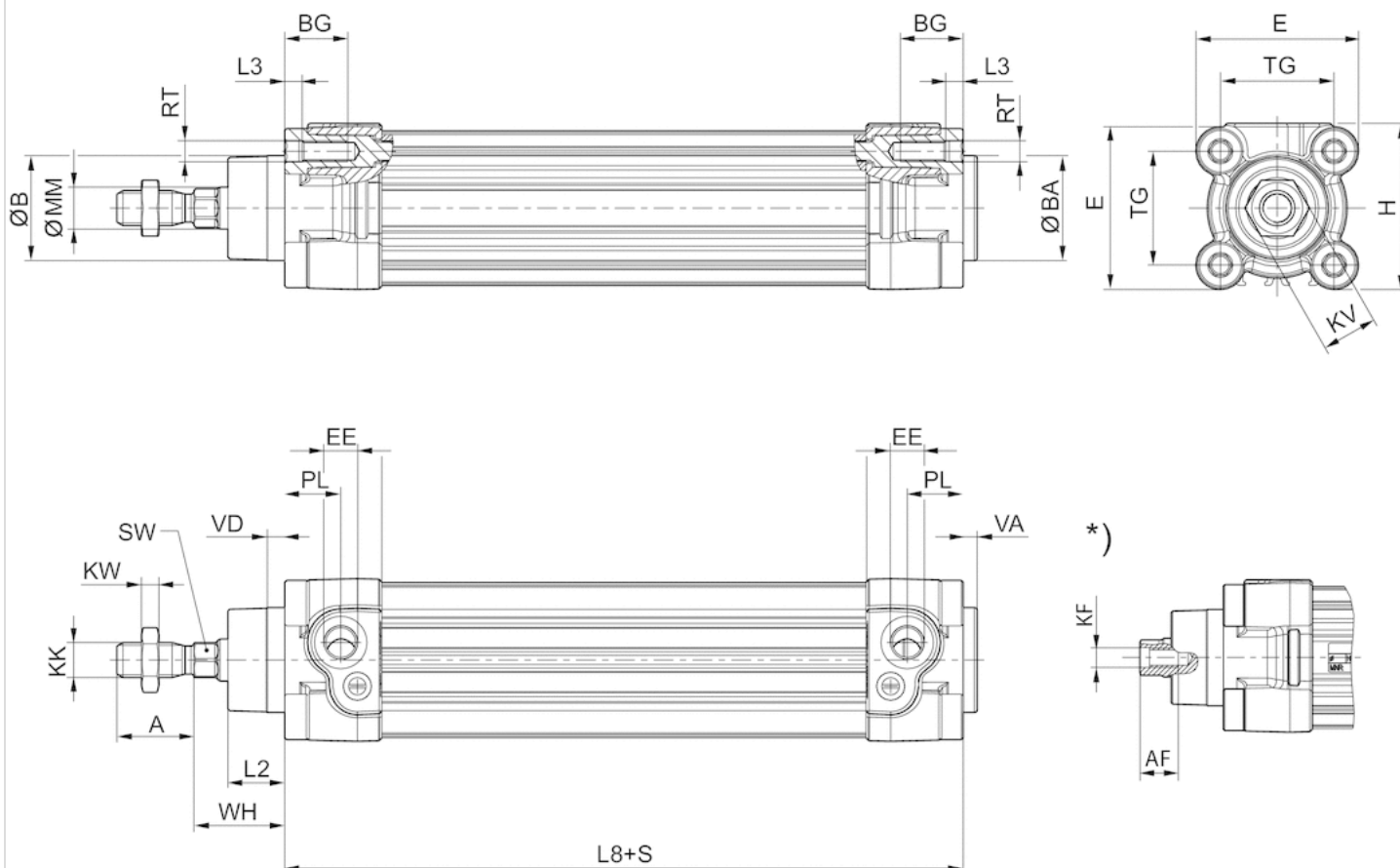

S = Hub

*) Für Zylinder mit Option Kolbenstange Innengewinde

Abmessungen

Kolben-Ø	A -2	ØB d11	ØBA d11	BG min.	E	EE inch	EE	H	KK inch	KK
32 mm	22	30	30	16	46.5	1/8 NPT	G 1/8	47.5	7/16 - 20 UNF	M10x1,25
40 mm	24	35	35	16	53	1/4 NPT	G 1/4	53	1/2 - 20 UNF	M12x1,25
50 mm	32	40	40	16	65	1/4 NPT	G 1/4	65	3/4 - 16 UNF	M16x1,5
63 mm	32	45	45	16	75	3/8 NPT	G 3/8	75	3/4 - 16 UNF	M16x1,5
80 mm	40	45	45	17	95	3/8 NPT	G 3/8	95	3/4 - 16 UNF	M20x1,5

Kolben-Ø	A -2	ØB d11	ØBA d11	BG min.	E	EE inch	EE	H	KK inch	KK
100 mm	40	55	55	17	115	1/2 NPT	G 1/2	115	3/4 - 16 UNF	M20x1,5
125 mm	54	60	60	20	140	1/2 NPT	G 1/2	140	1 - 14 UNF	M27x2

Kolben-Ø	KV	KW	ØMM f8	PL	L2	L3 ±0,5	L8	RT	SW	TG	VA -1	VD	WH
32 mm	16	5	12	16	16.25	4.5	94±0,4	M6	10	32,5±0,5	4	5	26±1,4
40 mm	18	6	16	20	18.25	4.5	105±0,7	M6	13	38±0,5	4	5	30±1,4
50 mm	24	8	20	19	25	4.5	106±0,7	M8	17	46,5±0,6	4	5	37±1,4
63 mm	24	8	20	24	25	4.5	121±0,8	M8	17	56,5±0,7	4	5	37±1,8
80 mm	30	10	25	23.5	33	0	128±0,8	M10	22	72±0,7	4	5	46±1,8
100 mm	30	10	25	25	36	0	138±1	M10	22	89±0,7	4	5	51±1,8
125 mm	41	13.5	32	33	45	0	160±1	M12	27	110±1,1	6	7	65±2,2

Diagramme

Dämpfungsdiagramm

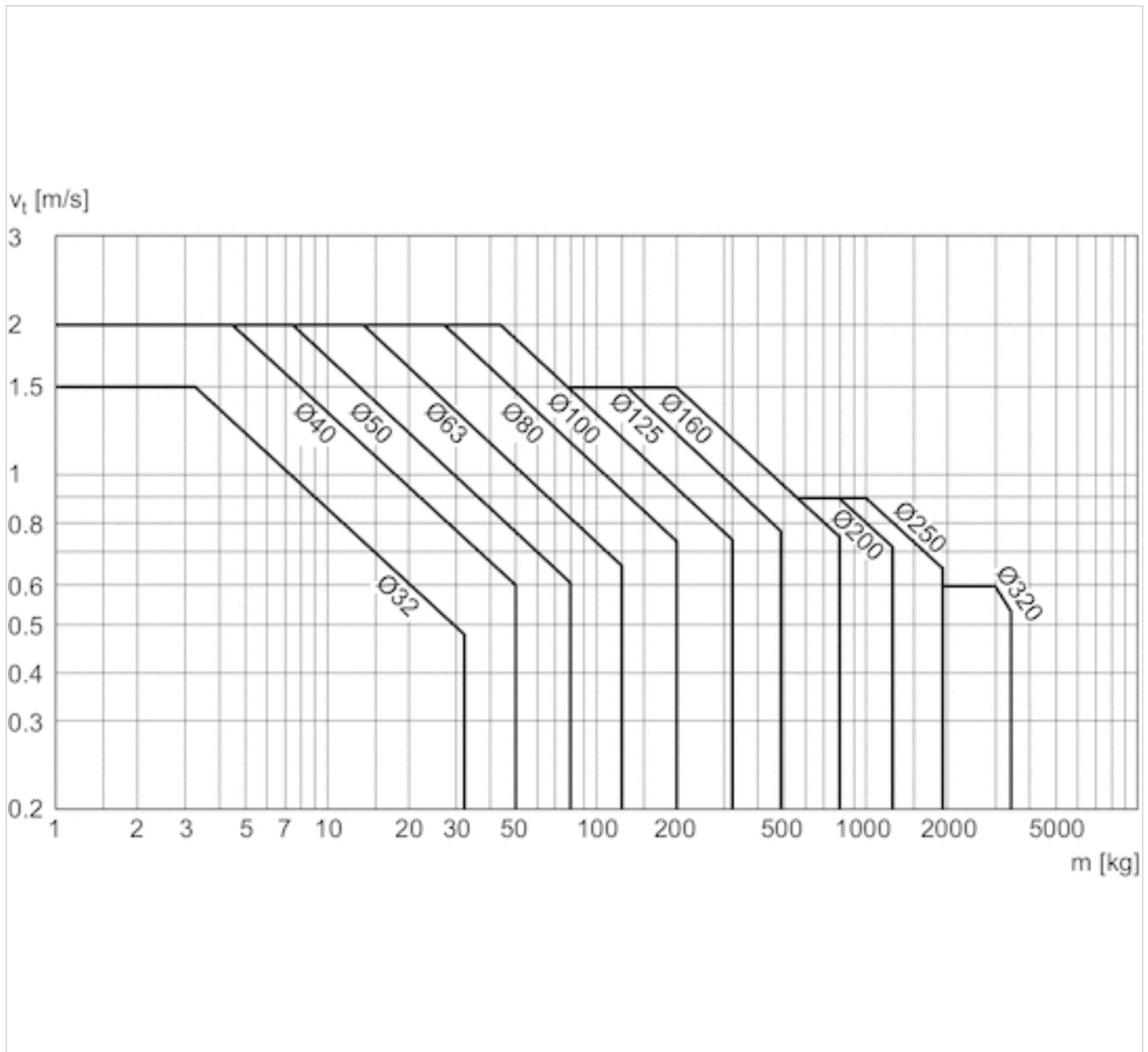

v = Kolbengeschwindigkeit [m/s]

m = Dämpfbare Masse [kg]

Zubehörübersicht

Übersichtszeichnung

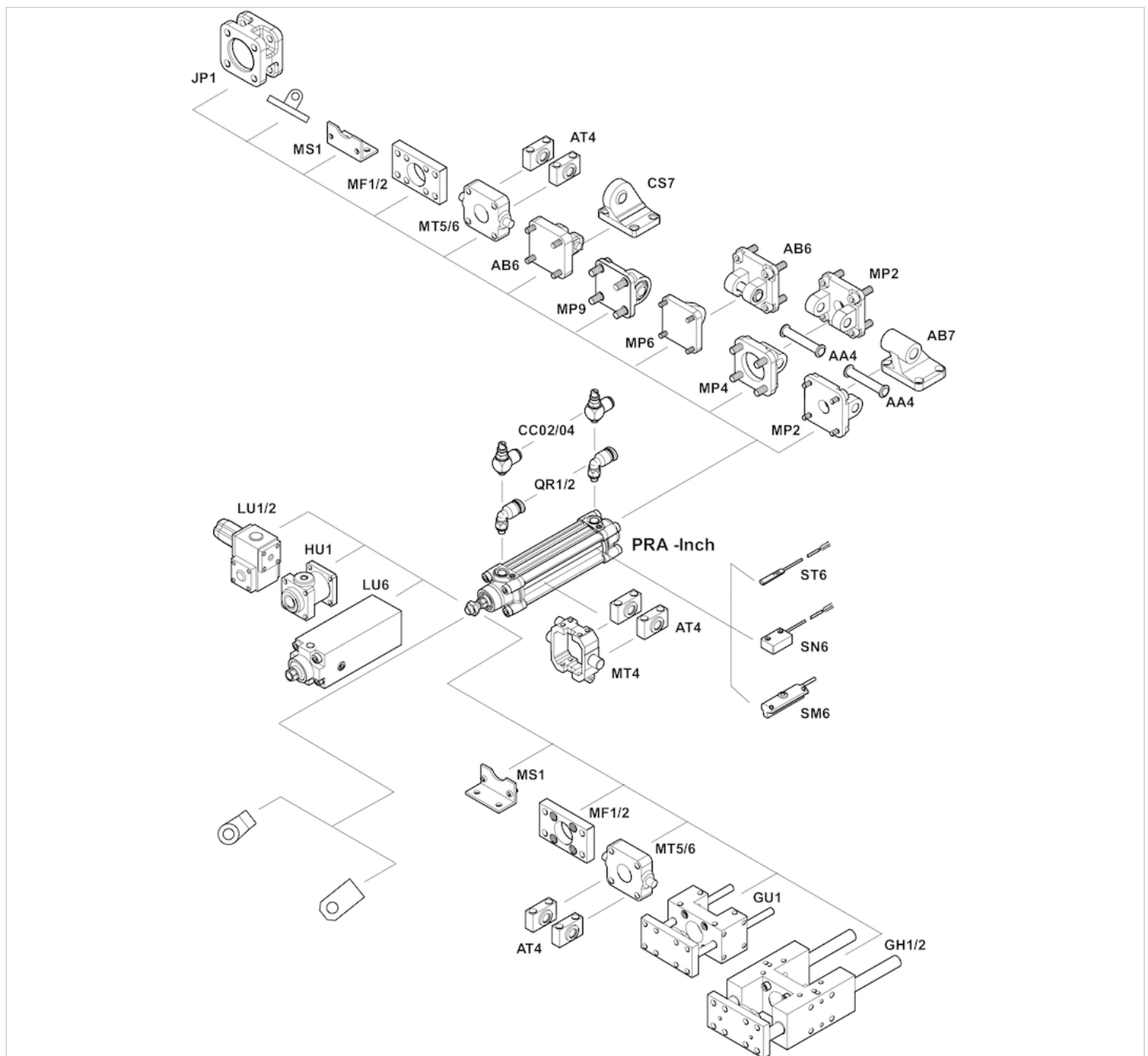

HINWEIS:

Diese Übersichtszeichnung dient zur Orientierung, an welcher Stelle die unterschiedlichen Zubehörteile am Zylinder befestigt werden können. Dazu wurde die Darstellung vereinfacht. Eine konkrete Ableitung maßlicher Gegebenheiten ist deshalb nicht zulässig.

Efficient pneumatic solutions, our program: cylinders and drives, valves and valve systems, air supply management



Visit us: [Emerson.com/Aventics](https://www.emerson.com/Aventics)

Your local contact: [Emerson.com/contactus](https://www.emerson.com/contactus)



Emerson.com



[Facebook.com/EmersonAutomationSolutions](https://www.facebook.com/EmersonAutomationSolutions)



[LinkedIn.com/company/Emerson-Automation-Solutions](https://www.linkedin.com/company/Emerson-Automation-Solutions)



[Twitter.com/EMR_Automation](https://twitter.com/EMR_Automation)

An example configuration is depicted on the title page. The delivered product may thus vary from that in the illustration. Subject to change. This Document, as well as the data, specifications and other information set forth in it, are the exclusive property of AVENTICS GmbH. It may not be reproduced or given to third parties without its consent. Only use the AVENTICS products shown in industrial applications. Read the product documentation completely and carefully before using the product. Observe the applicable regulations and laws of the respective country. When integrating the product into applications, note the system manufacturer's specifications for safe use of the product. The data specified only serve to describe the product. No statements concerning a certain condition or suitability for a certain application can be derived from our information. The information given does not release the user from the obligation of own judgement and verification. It must be remembered that the products are subject to a natural process of wear and aging.

The Emerson logo is a trademark and service mark of Emerson Electric Co. Brand logotype are registered trademarks of one of the Emerson family of companies. All other marks are the property of their respective owners. © 2020 Emerson Electric Co. All rights reserved.
2020-12



CONSIDER IT SOLVED™