

# ISO 21287, Series CCL-IC

- ISO 21287
- Ø 16-100 mm
- Ports M5 G 1/8
- double-acting
- with magnetic piston
- Cushioning elastic
- Piston rod External thread
- ATEX optional
- Optionally heat-resistant



Standards	ISO 21287
Certificates	ATEX optional
Compressed air connection	Internal thread
Working pressure min./max.	1 ... 10 bar
Ambient temperature min./max.	-20 ... 80 °C
Medium temperature min./max.	-20 ... 80 °C
Medium	Compressed air
Max. particle size	50 µm
Oil content of compressed air	0 ... 5 mg/m <sup>3</sup>
Pressure for determining piston forces	6.3 bar



## Technical data

Piston Ø Piston rod thread Ports Piston rod Ø	16 mm M6 M5 8 mm	20 mm M8 M5 10 mm	25 mm M8 M5 10 mm	32 mm M10x1,25 G 1/8 12 mm	40 mm M10x1,25 G 1/8 12 mm	50 mm M12x1,25 G 1/8 16 mm
Stroke 5	R480668683	R480668692	R480668701	R480668710	R480668723	R480668736
10	R480668684	R480668693	R480668702	R480668711	R480668724	R480668737
15	R480668685	R480668694	R480668703	R480668712	R480668725	R480668738
20	R480668686	R480668695	R480668704	R480668713	R480668726	R480668739
25	R480668687	R480668696	R480668705	R480668714	R480668727	R480668740
30	R480668688	R480668697	R480668706	R480668715	R480668728	R480668741
40	R480668689	R480668698	R480668707	R480668716	R480668729	R480668742
50	R480668690	R480668699	R480668708	R480668717	R480668730	R480668743
60	R480668691	R480668700	R480668709	R480668718	R480668731	R480668744
80	-	-	-	R480668719	R480668732	R480668745
100	-	-	-	R480668720	R480668733	R480668746
125	-	-	-	R480668721	R480668734	R480668747
150	-	-	-	R480668722	R480668735	R480668748

Piston Ø Piston rod thread Ports Piston rod Ø	63 mm M12x1,25 G 1/8 16 mm	80 mm M16x1,5 G 1/8 20 mm	100 mm M16x1,5 G 1/8 25 mm
Stroke 5	R480668749	-	R480668774
10	R480668750	R480668762	R480668775
15	R480668751	R480668763	R480668776
20	R480668752	R480668764	R480668777
25	R480668753	R480668765	R480668778
30	R480668754	R480668766	R480668779
40	R480668755	R480668767	R480668780
50	R480668756	R480668768	R480668781
60	R480668757	R480668769	R480668782
80	R480668758	R480668770	R480668783
100	R480668759	R480668771	R480668784
125	R480668760	R480668772	R480668785
150	R480668761	R480668773	R480668786

## Technical data

Piston Ø	16 mm	20 mm	25 mm	32 mm	40 mm	50 mm	63 mm
Retracting piston force	95 N	148 N	260 N	435 N	720 N	1110 N	1837 N
Extracting piston force	127 N	198 N	309 N	507 N	792 N	1237 N	1964 N
Impact energy	0,15 J	0,2 J	0,3 J	0,5 J	0,7 J	1 J	1,3 J
Weight 0 mm stroke	0,084 kg	0,145 kg	0,176 kg	0,309 kg	0,401 kg	0,59 kg	0,801 kg
Weight +10 mm stroke	0,016 kg	0,019 kg	0,021 kg	0,035 kg	0,04 kg	0,055 kg	0,062 kg
Stroke max.	300 mm	300 mm	300 mm	300 mm	300 mm	300 mm	300 mm

Piston Ø	80 mm	100 mm
Retracting piston force	2969 N	4639 N
Extracting piston force	3167 N	4948 N
Impact energy	1,8 J	2,5 J
Weight 0 mm stroke	1,42 kg	2,33 kg
Weight +10 mm stroke	0,087 kg	0,108 kg
Stroke max.	500 mm	500 mm

## Technical information

The pressure dew point must be at least 15 °C under ambient and medium temperature and may not exceed 3 °C .

The oil content of compressed air must remain constant during the life cycle.

ATEX-certified cylinders with identification II 2G Ex h IIC T4 Gb / II 2D Ex h IIIC T135°C Db\_X can be generated in the Internet configurator.

The material for heat-resistant scraper and seal variants (ambient temperature: -10 °C ... 120 °C) is fluorocautchouc.

Further options can be generated in the Internet configurator.

LW\*/SW\* Hexagonal key required

## Technical information

Material	
Cylinder tube	Aluminum, anodized
Piston rod	Stainless steel
Front cover	Aluminum, anodized
End cover	Aluminum, anodized
Scraper	Polyurethane
Grease	AGF (NSF-H1)

# Dimensions

## Dimensions

**Ø16 - 63**

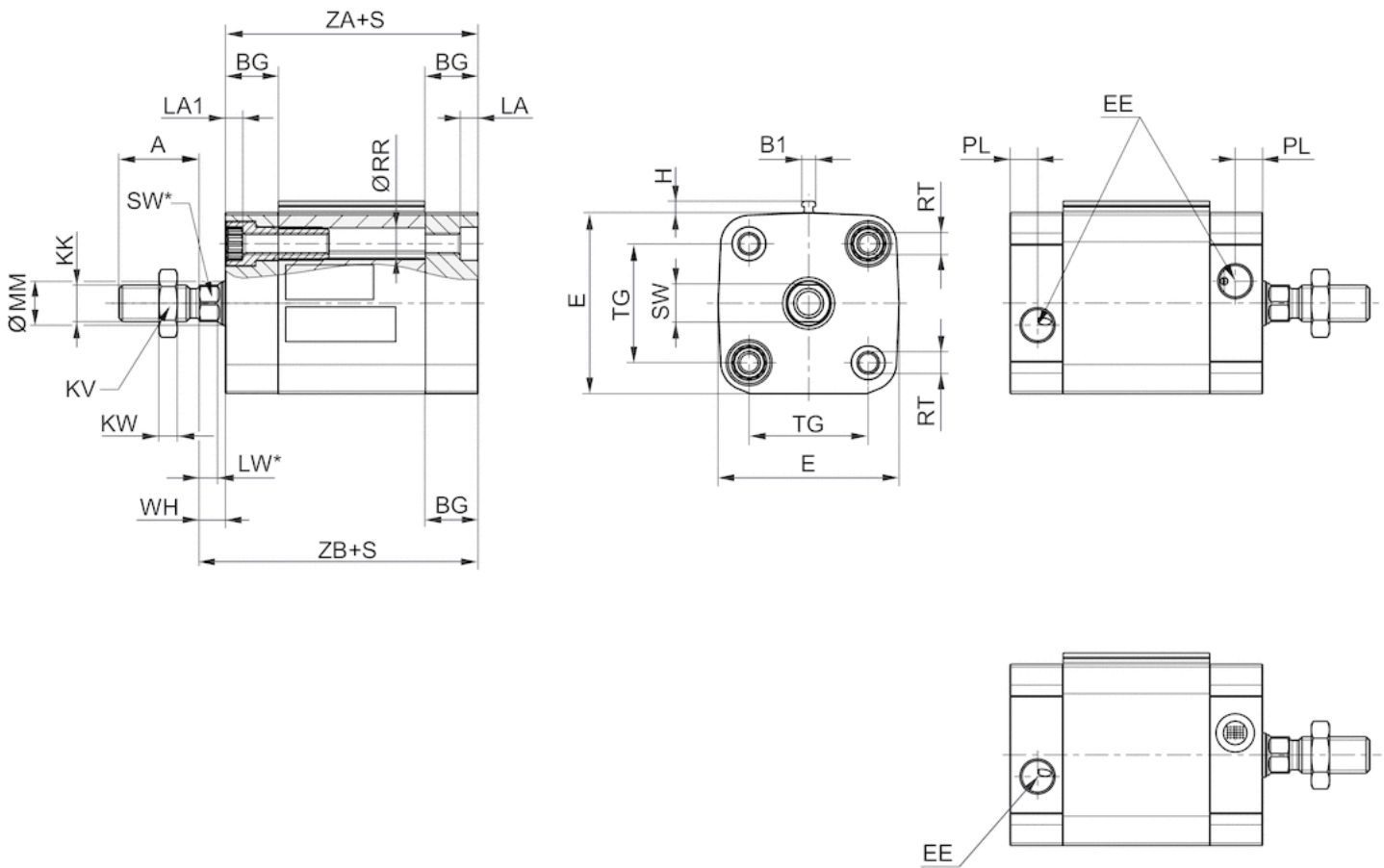

S = stroke

## Dimensions

Ø80 - 100

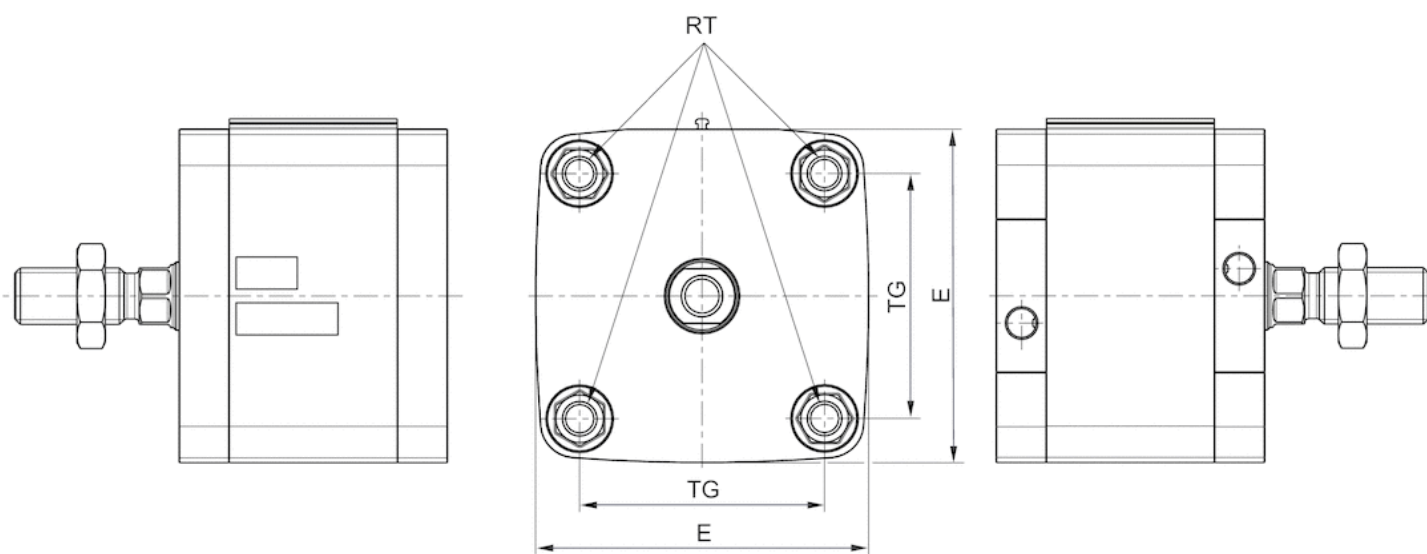

## Dimensions

Piston Ø	A	B1	BG min.	E	EE	H	KK	KV	KW	LA	LA1	LW	LW*	MM f8
16 mm	12	3.8	15	29	M5	3.1	M6	10	3.2	3.5	3.5	3.2	3.2	8
20 mm	16	3.8	15	36.5	M5	3.1	M8	13	4	4.8	4.6	3.7	3.7	10
25 mm	16	3.8	15	40.5	M5	3.1	M8	13	4	4.8	4.6	3.7	3.7	10
32 mm	19	3.8	16	49.5	G1/8	3.1	M10x1,25	17	5	4.8	4.8	5	5*	12
40 mm	19	3.8	16	57.5	G1/8	3.1	M10x1,25	17	5	4.8	4.8	5	5*	12
50 mm	22	3.8	16	69.5	G1/8	3.1	M12x1,25	18	6	4.8	4.8	5.7	4,8*	16
63 mm	22	3.8	16	79.5	G1/8	3.1	M12x1,25	18	6	4.8	4.8	5.7	4,8*	16
80 mm	28	3.8	17	98 / ISO 21287:96	G1/8	3.1	M16x1,5	24	8	0	0	7	6,4*	20
100 mm	28	3.8	17	115.5	G1/8	3.1	M16x1,5	24	8	0	0	7.5	6,4*	25

Piston Ø	PL	RR min.	RT	SW	SW*	TG	WH	ZA +S	ZB+S
16 mm	5	3.2	M4	7	7	18 ±0,4	4,8 ±1,4	36	40.8
20 mm	5	4.1	M5	8	8	22 ±0,4	6 ±1,4	37	43
25 mm	5	4.1	M5	8	8	26 ±0,4	6 ±1,4	39	45
32 mm	7.5	5.1	M6	10	10*	32,5 ±0,5	7 ±1,6	44	51
40 mm	7.5	5.1	M6	10	10*	38 ±0,5	7 ±1,6	45	52
50 mm	7.5	6.4	M8	13	13*	46,5 ±0,6	8 ±1,6	45.5	53.5
63 mm	7.5	6.4	M8	13	13*	56,5 ±0,7	8 ±1,6	49	57
80 mm	7.5	8.4	M10	16	16*	72 ±0,7	10 ±2	54	64
100 mm	7.5	8.4	M10	21	21*	89 ±0,7	10 ±2	67	77

## Accessories overview

### Overview drawing

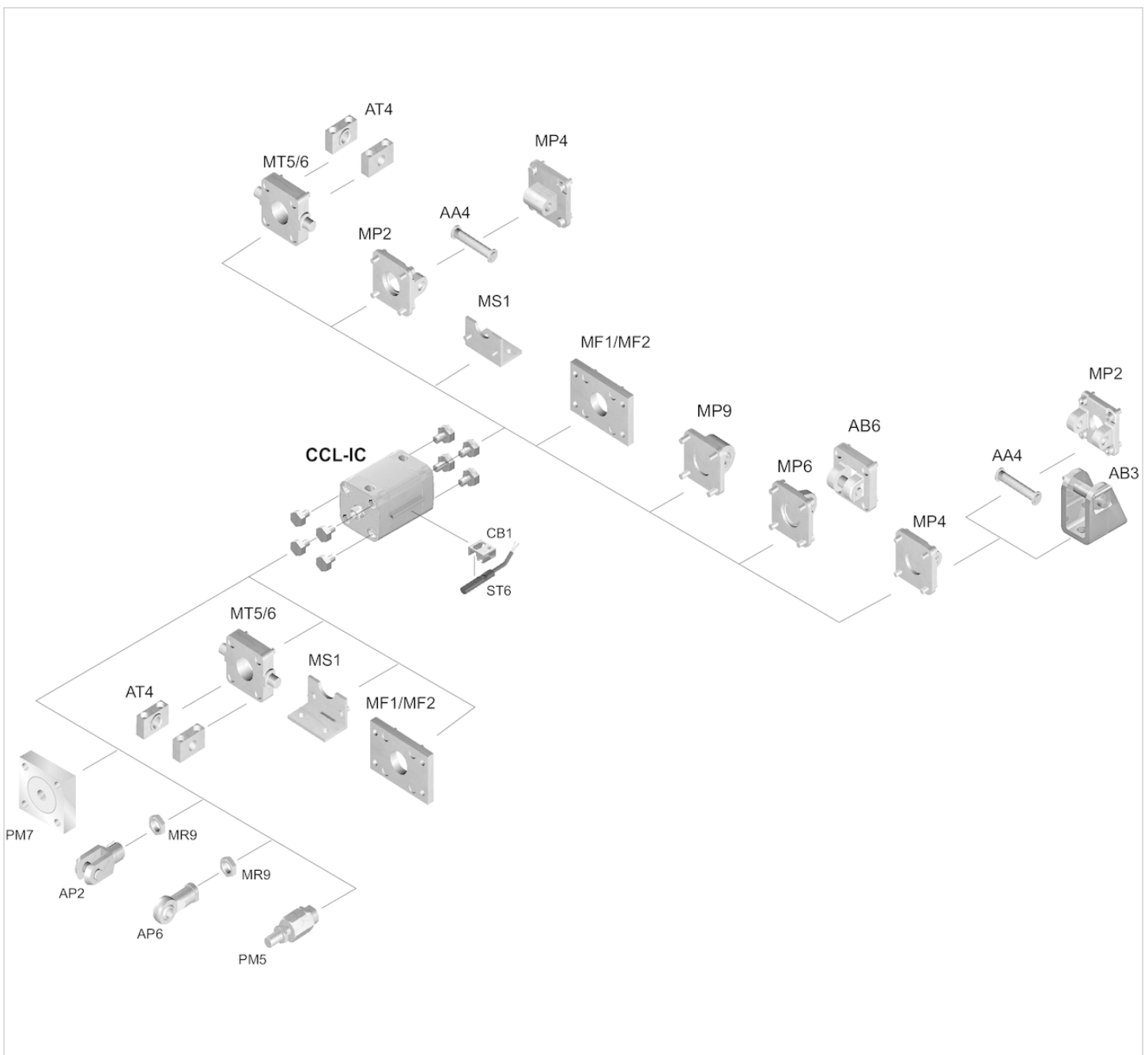

NOTE:

This overview drawing is only for orientation to indicate where the various accessory parts can be fastened to the cylinder. The illustration has been simplified for this purpose. It is thus not possible to derive the dimensions from this overview.

# Efficient pneumatic solutions, our program: cylinders and drives, valves and valve systems, air supply management



Visit us: [Emerson.com/Aventics](https://www.emerson.com/Aventics)

Your local contact: [Emerson.com/contactus](https://www.emerson.com/contactus)



Emerson.com



[Facebook.com/EmersonAutomationSolutions](https://www.facebook.com/EmersonAutomationSolutions)



[LinkedIn.com/company/Emerson-Automation-Solutions](https://www.linkedin.com/company/Emerson-Automation-Solutions)



[Twitter.com/EMR\\_Automation](https://twitter.com/EMR_Automation)

An example configuration is depicted on the title page. The delivered product may thus vary from that in the illustration. Subject to change. This Document, as well as the data, specifications and other information set forth in it, are the exclusive property of AVENTICS GmbH. It may not be reproduced or given to third parties without its consent. Only use the AVENTICS products shown in industrial applications. Read the product documentation completely and carefully before using the product. Observe the applicable regulations and laws of the respective country. When integrating the product into applications, note the system manufacturer's specifications for safe use of the product. The data specified only serve to describe the product. No statements concerning a certain condition or suitability for a certain application can be derived from our information. The information given does not release the user from the obligation of own judgement and verification. It must be remembered that the products are subject to a natural process of wear and aging.

The Emerson logo is a trademark and service mark of Emerson Electric Co. Brand logotype are registered trademarks of one of the Emerson family of companies. All other marks are the property of their respective owners. © 2020 Emerson Electric Co. All rights reserved.  
2020-12



**CONSIDER IT SOLVED™**