

Zugankerzylinder ISO 15552, Serie TRB - inch

- Ø 32-125 mm
- Anschlüsse 1/8 NPT 1/4 NPT 3/8 NPT 1/2 NPT
- doppelwirkend
- mit Magnetkolben
- Dämpfung pneumatisch
- Kolbenstange Außengewinde
- ATEX optional

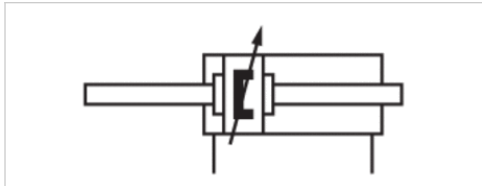

Druckluftanschluss	Innengewinde
Umgebungstemperatur min./max.	-20 ... 80 °C
Mediumtemperatur min./max.	-20 ... 80 °C
Medium	Druckluft
Max. Partikelgröße	50 µm
Ölgehalt der Druckluft	0 ... 5 mg/m ³
Druck zur Bestimmung der Kolbenkräfte	6.3 bar

Technische Daten

Kolben-Ø Kolbenstangengewinde Anschlüsse Kolbenstangen-Ø	32 mm 7/16-20 UNF 1/8 NPT 12 mm	40 mm 1/2-20 UNF 1/4 NPT 16 mm	50 mm 3/4-16 UNF 1/4 NPT 20 mm	63 mm 3/4-16 UNF 3/8 NPT 20 mm	80 mm 3/4-16 UNF 3/8 NPT 25 mm	100 mm 3/4-16 UNF 1/2 NPT 25 mm
Hub 25.4	R480176773	R480176861	R480176949	R480177037	R480177118	R480177210
50.8	R480176779	R480176863	R480176951	R480177044	R480177133	R480177214
76.2	R480176785	R480176872	R480176961	R480177052	R480177135	R480177222
101.6	R480176792	R480176878	R480176967	R480177058	R480177149	R480177233
127	R480176804	R480176893	R480176976	R480177063	R480177157	R480177241
152.4	R480176809	R480176896	R480176988	R480177071	R480177160	R480177246
177.8	R480176814	R480176903	R480176996	R480177084	R480177167	R480177259
203.2	R480176827	R480176916	R480177001	R480177088	R480177180	R480177268
228.6	R480176837	R480176921	R480177012	R480177095	R480177187	R480177276
254	R480176839	R480176931	R480177014	R480177108	R480177190	R480177284
304.8	R480176851	R480176939	R480177028	R480177111	R480177204	R480177293

Kolben-Ø Kolbenstangengewinde Anschlüsse Kolbenstangen-Ø	125 mm 1-14 UNF 1/2 NPT 32 mm
Hub 25.4	R480177297
50.8	R480177304
76.2	R480177311
101.6	R480177321
127	R480177332
152.4	R480177337
177.8	R480177348
203.2	R480177356
228.6	R480177364
254	R480177366
304.8	R480177381

Technische Daten

Kolben-Ø	32 mm	40 mm	50 mm
Kolbenkraft einfahrend	435 N	660 N	1035 N
Kolbenkraft ausfahrend	435 N	660 N	1035 N
Dämpfungslänge	16,5 mm	15 mm	17 mm
Dämpfungsenergie	4,8 J	9 J	15 J
Gewicht 0 mm Hub	0,52 kg	0,82 kg	1,42 kg
Gewicht +10 mm Hub	0,033 kg	0,046 kg	0,061 kg
Betriebsdruck min./max.	2 ... 10 bar	2 ... 10 bar	2 ... 10 bar
Zuganker	Nichtrostender Stahl	Nichtrostender Stahl	Stahl verzinkt
Hub max.	1600 mm	1900 mm	2100 mm

Kolben-Ø	63 mm	80 mm	100 mm	125 mm
Kolbenkraft einfahrend	1765 N	2855 N	4635 N	7220 N
Kolbenkraft ausfahrend	1765 N	2855 N	4635 N	7220 N
Dämpfungslänge	16,5 mm	19,5 mm	19,5 mm	22 mm
Dämpfungsenergie	27 J	54 J	88 J	140 J
Gewicht 0 mm Hub	1,7 kg	2,67 kg	3,7 kg	9 kg
Gewicht +10 mm Hub	0,077 kg	0,099 kg	0,104 kg	0,26 kg
Betriebsdruck min./max.	2 ... 10 bar	2 ... 10 bar	2 ... 10 bar	2 ... 10 bar
Zuganker	Stahl verzinkt	Stahl verzinkt	Stahl verzinkt	Stahl verzinkt
Hub max.	2500 mm	2800 mm	2800 mm	2750 mm

Technische Informationen

Der Drucktaupunkt muss mindestens 15 °C unter der Umgebungs- und Mediumtemperatur liegen und darf max. 3 °C betragen. Der Ölgehalt der Druckluft muss über die gesamte Lebensdauer konstant bleiben.

Verwenden Sie ausschließlich von AVENTICS zugelassene Öle. Weitere Informationen finden Sie im Dokument „Technische Informationen“ (erhältlich im MediaCentre).

Technische Informationen

Werkstoff	
Zylinderrohr	Aluminium, eloxiert
Kolbenstange	Nichtrostender Stahl
Deckel vorne	Aluminium-Druckguss
Deckel hinten	Aluminium-Druckguss
Dichtung	Polyurethan
Mutter für Kolbenstange	Stahl, verzinkt
Abstreifer	Polyurethan
Zuganker	Nichtrostender Stahl Stahl, verzinkt
	Weitere Werkstoffangaben siehe Tabelle.

Abmessungen

Abmessungen

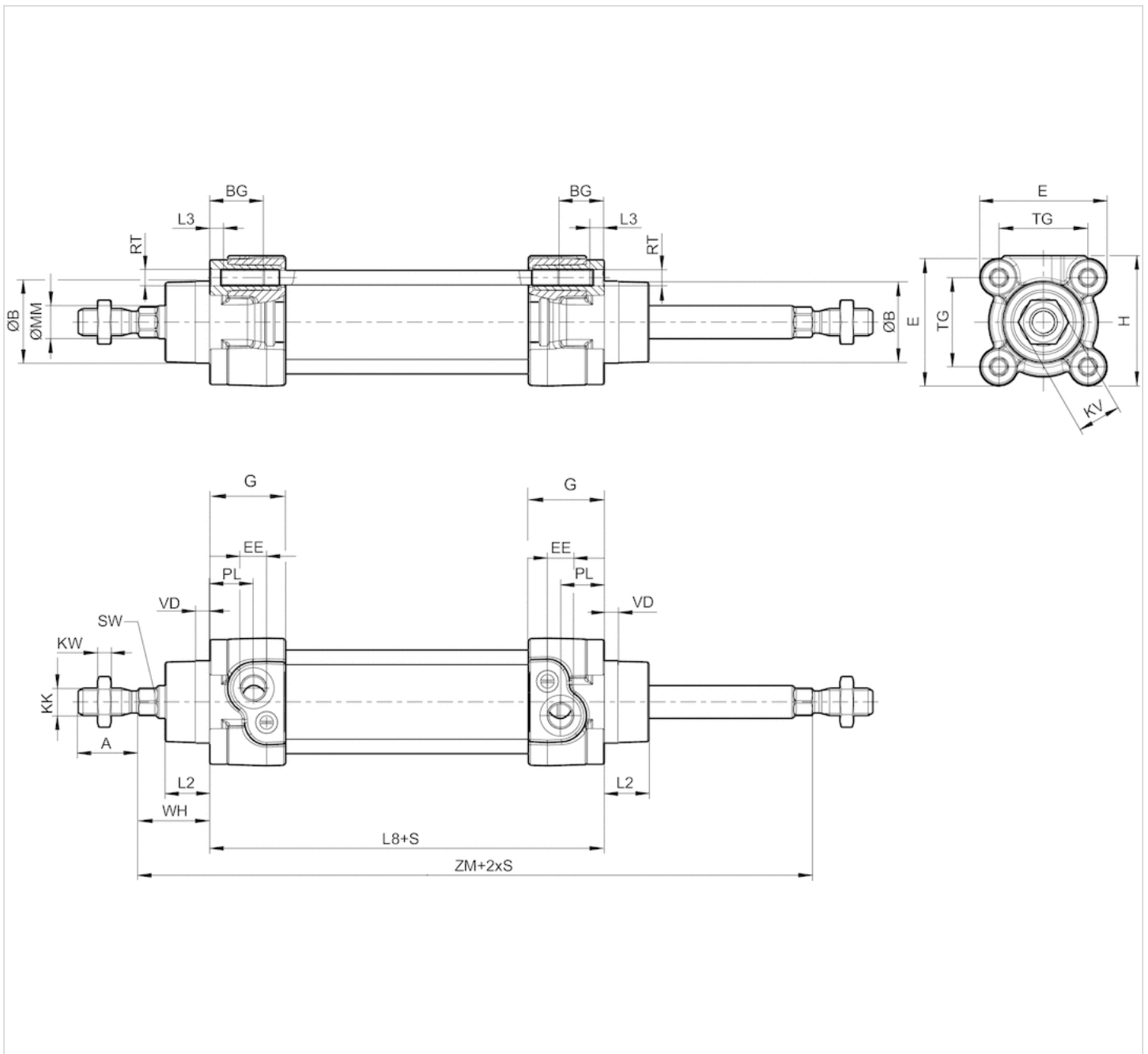

S = Hub

Abmessungen in inch

Ø [mm]	Ø [inch]	A -0,08	ØB d11	BG min.	E	EE	KK	G	H	KV	KW
32	1 1/4	0.87	1.18	0.63	1.83	1/8 NPT	7/16 - 20 UNF	1.09	1.87	0.63	0.2
40	1 1/2	0.94	1.38	0.63	2.09	1/4 NPT	1/2 - 20 UNF	1.31	2.09	0.71	0.24
50	2	1.26	1.57	0.63	2.56	1/4 NPT	3/4 - 16 UNF	1.22	2.56	0.94	0.31
63	2 1/2	1.26	1.77	0.63	2.95	3/8 NPT	3/4 - 16 UNF	1.22	2.95	0.94	0.31
80	3	1.57	1.77	0.67	3.74	3/8 NPT	3/4 - 16 UNF	1.51	3.74	1.18	0.39
100	4	1.57	2.17	0.67	4.53	1/2 NPT	3/4 - 16 UNF	1.51	4.53	1.18	0.39

Ø [mm]	Ø [inch]	A -0,08	ØB d11	BG min.	E	EE	KK	G	H	KV	KW
125	5	2.13	2.36	0.79	5.51	1/2 NPT	1 - 14 UNF	1.66	5.51	1.61	0.53

ØMM f8	PL	L2	L3 ±0,02	L8	RT	SW	TG	VD	WH	ZM
0.47	0.63	0.64	0.18	3.7±0.02	M6	0.39	1.28±0.02	0.2	26±1.4	5.75+0.12/0.06
0.63	0.79	0.72	0.18	4.13±0.03	M6	0.51	1.5±0.02	0.2	30±1.4	6.5+0.12/0.06
0.79	0.75	0.98	0.18	4.17±0.03	M8	0.67	1.83±0.02	0.2	37±1.4	7.09+0.12/0.06
0.79	0.94	0.98	0.18	4.76±0.03	M8	0.67	2.22±0.03	0.2	37±1.8	7.68+0.12/0.06
0.98	0.93	1.3	0	5.04±0.03	M10	0.87	2.83±0.03	0.2	46±1.8	8.66+0.12/0.06
0.98	0.98	1.42	0	5.43±0.04	M10	0.87	3.5±0.03	0.2	51±1.8	9.45+0.08/0.08
1.26	1.3	1.77	0	6.3±0.04	M12	1.06	4.33±0.04	0.28	65±2.2	11.42+0.08/0.08

Diagramme

Dämpfungsdiagramm

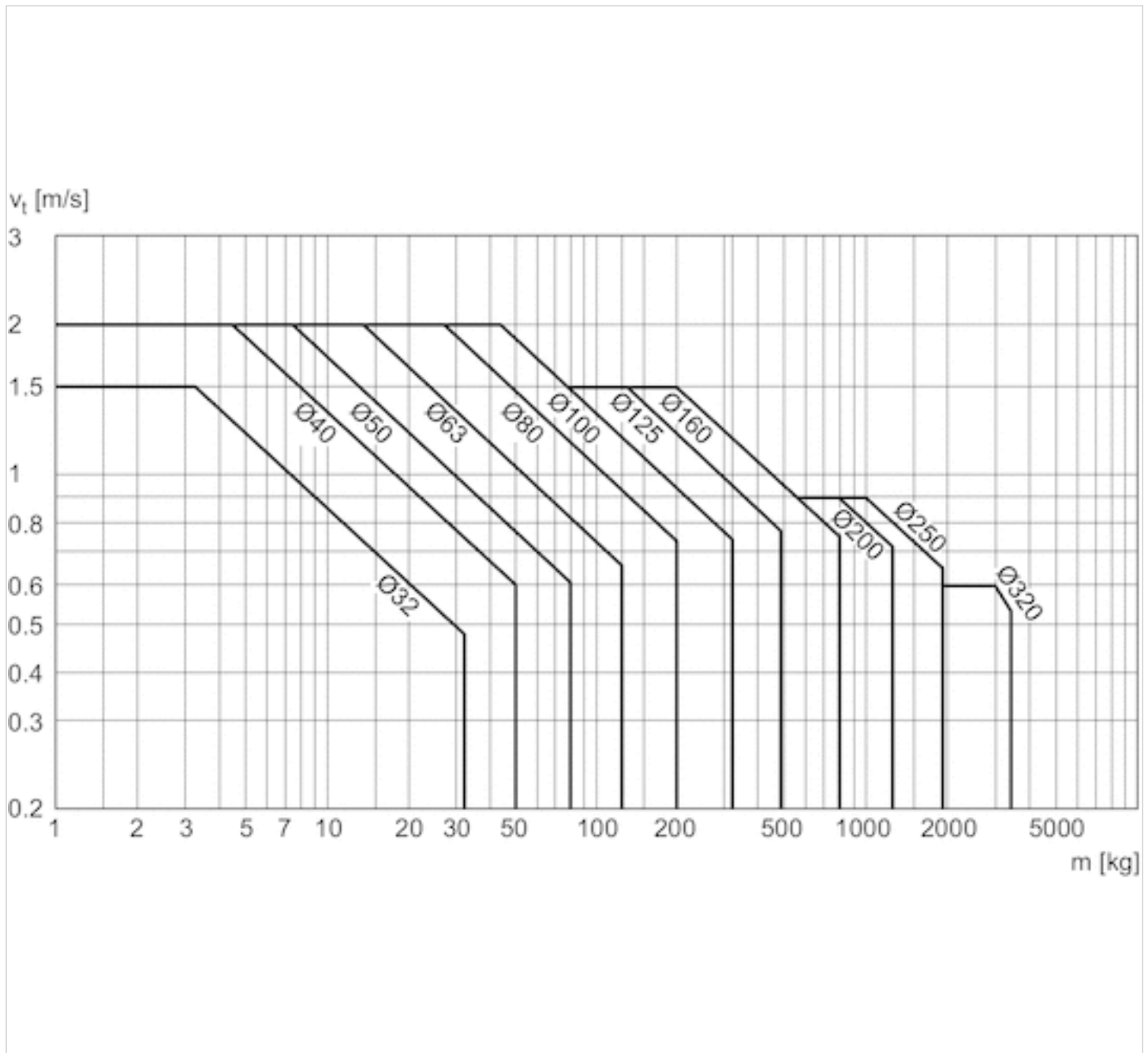

v = Kolbengeschwindigkeit [m/s]

m = Dämpfbare Masse [kg]

Zubehörübersicht

Übersichtszeichnung

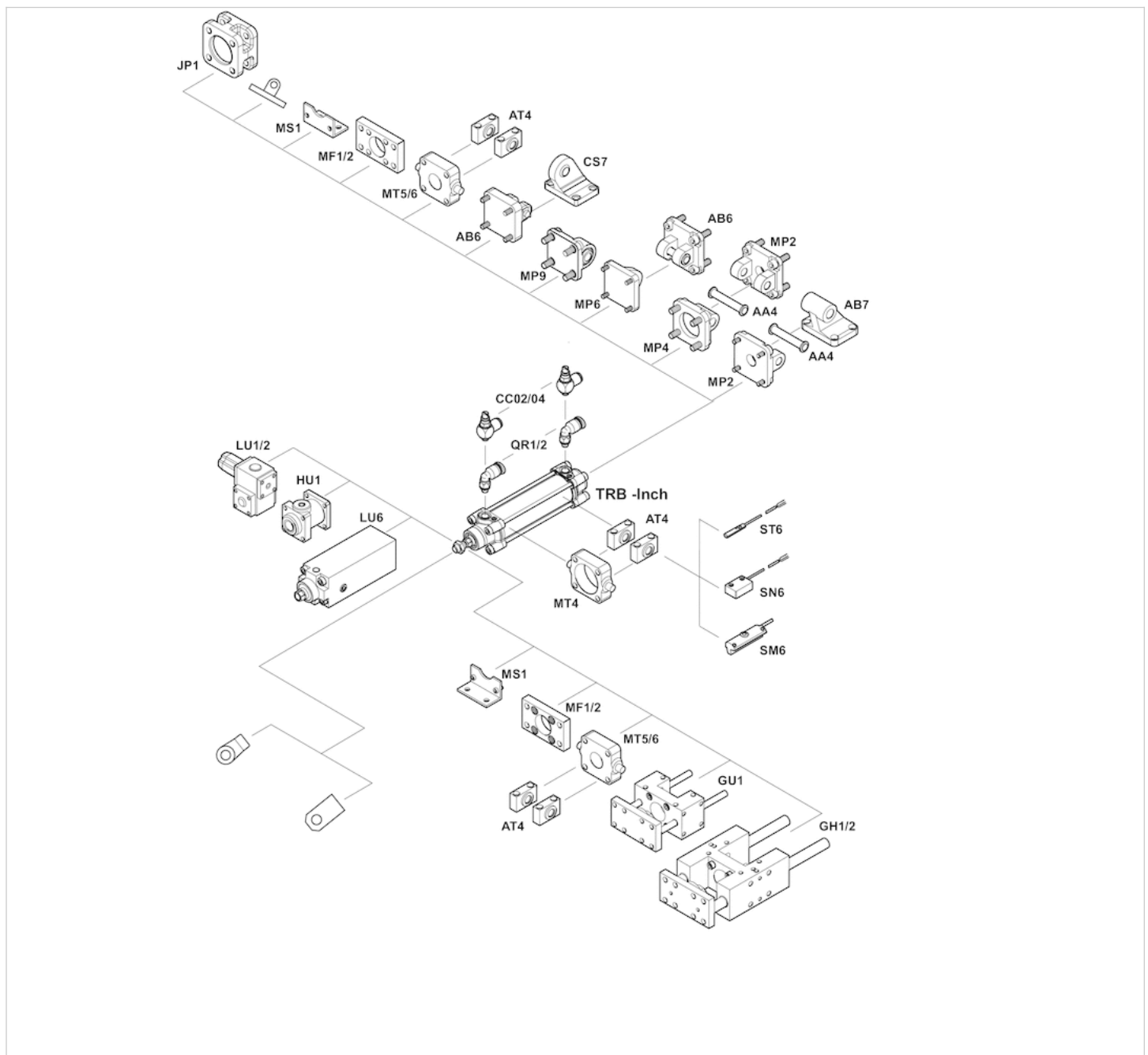

HINWEIS:

Diese Übersichtszeichnung dient zur Orientierung, an welcher Stelle die unterschiedlichen Zubehörteile am Zylinder befestigt werden können. Dazu wurde die Darstellung vereinfacht. Eine konkrete Ableitung maßlicher Gegebenheiten ist deshalb nicht zulässig.

Efficient pneumatic solutions, our program: cylinders and drives, valves and valve systems, air supply management



Visit us: [Emerson.com/Aventics](https://www.emerson.com/Aventics)

Your local contact: [Emerson.com/contactus](https://www.emerson.com/contactus)



[Emerson.com](https://www.emerson.com)



[Facebook.com/EmersonAutomationSolutions](https://www.facebook.com/EmersonAutomationSolutions)



[LinkedIn.com/company/Emerson-Automation-Solutions](https://www.linkedin.com/company/Emerson-Automation-Solutions)



[Twitter.com/EMR_Automation](https://twitter.com/EMR_Automation)

An example configuration is depicted on the title page. The delivered product may thus vary from that in the illustration. Subject to change. This Document, as well as the data, specifications and other information set forth in it, are the exclusive property of AVENTICS GmbH. It may not be reproduced or given to third parties without its consent. Only use the AVENTICS products shown in industrial applications. Read the product documentation completely and carefully before using the product. Observe the applicable regulations and laws of the respective country. When integrating the product into applications, note the system manufacturer's specifications for safe use of the product. The data specified only serve to describe the product. No statements concerning a certain condition or suitability for a certain application can be derived from our information. The information given does not release the user from the obligation of own judgement and verification. It must be remembered that the products are subject to a natural process of wear and aging.

The Emerson logo is a trademark and service mark of Emerson Electric Co. Brand logotype are registered trademarks of one of the Emerson family of companies. All other marks are the property of their respective owners. © 2020 Emerson Electric Co. All rights reserved.
2020-12



CONSIDER IT SOLVED™